

Team	Runs Allowed/Game				Total	÷	Defensive innings/game				Total	=	Runs-Allowed	Pool
													Ratio	
1 Stbg National	12	6	10	8	36	÷	5	6	6	5	22	=	1.6364	A
2 E Stbg North	11	12	16	6	45	÷	5	5	5	6	21	=	2.1429	A
3 Slatebelt	1	16	8	4	29	÷	6	6	5	6	23	=	1.2609	A
4 Dingmans	9	2	6	7	24	÷	6	5	6	6	23	=	1.0435	A
5 WE American	13	6	5	16	40	÷	6	5	6	6	23	=	1.7391	A
6 Pen Argyl	9	1	4		14	÷	5	6	6		17	=	0.8235	B
7 PM East	0	2	9		11	÷	6	6	5		17	=	0.6471	B
8 Stbg American	3	4	8		15	÷	6	5	6		17	=	0.8824	B
9 E Stbg	7	1	12		20	÷	6	6	6		18	=	1.1111	B
10 WE National	2	10	5		17	÷	5	6	6		17	=	1.0000	C
11 PM West	12	18	2		32	÷	5	6	6		17	=	1.8824	C
12 Tobyhanna	18	11	5		34	÷	5	5	6		16	=	2.1250	C
13 Big Pocono	0	6	6		12	÷	5	6	5		16	=	0.7500	C

Tie Breaker Procedure 1- Head to Head 2- Runs-Allowed Ratio (RAR)

Teams (2) Advancing to Double Elimination Round from each pool

6 Team Double Elimination Bracket PA District 29 6/5/2011

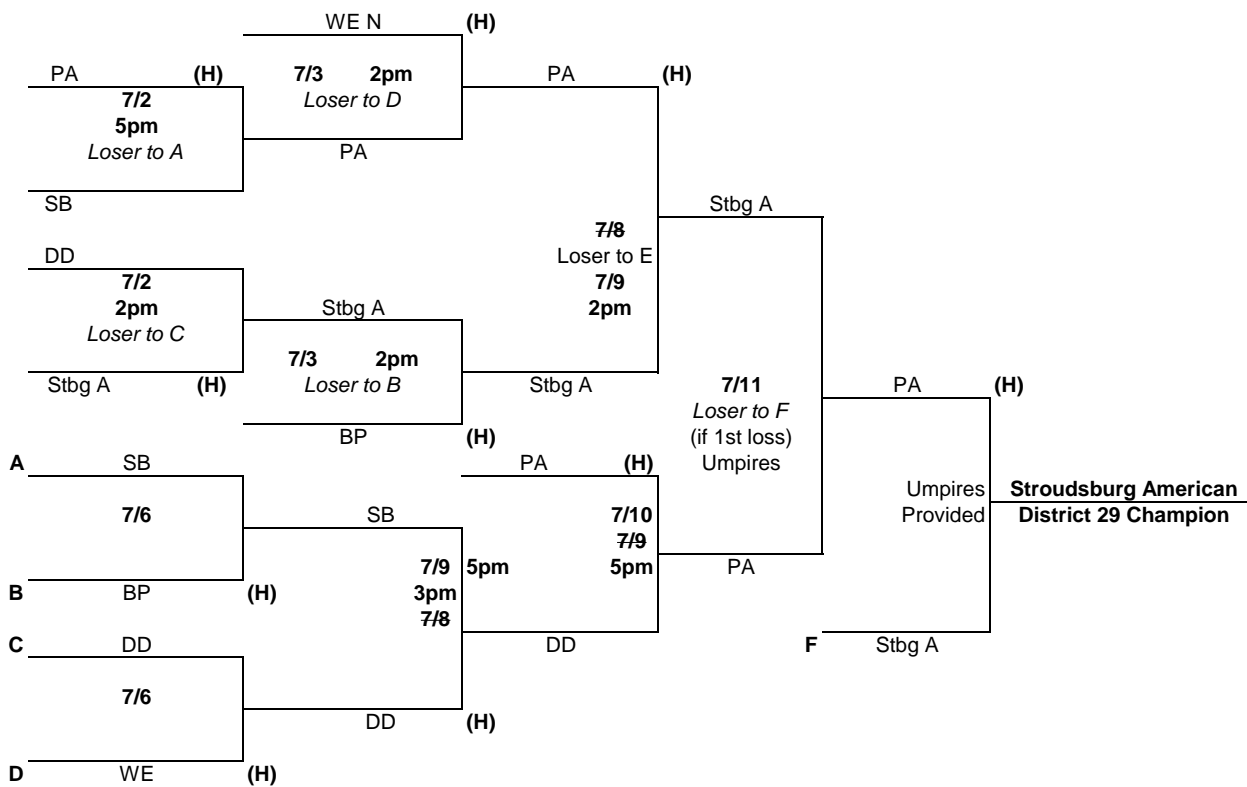

(all games begin at 6:00pm unless otherwise noted)